

SPECIFICATIONS**GENERAL-**

Projected and Casement, and Fixed windows shall be Marlin series #7505 as manufactured by Marlin windows, and shall conform to ANSI/AAMA-101-93 structural HC40. Series #7505 shall have a condensation factor of 56.

MATERIALS-

All frame and sash members shall be aluminum extrusions of 6063-T5 alloy & temper with a minimum wall thickness of .094". Frame and sash members shall have a rigid polyurethane "thermal-barrier" as an integral part of the extrusion which eliminates all direct contact between interior and exterior aluminum sections. Glazing stops to be extruded aluminum with a minimum wall thickness of .050".

FINISH-

Standard architectural Class II anodic color conforming to Aluminum Association AA-M12-C22-A34 for dark bronze or AA-M12-C22-A31 for clear anodize. (Architectural Class I anodic finishes and organic coatings available - specify).

CONSTRUCTION-

Frame members shall be 3 3/8" in depth. Frame and vent corners shall be fabricated to form tight mitered joints. All intermediate frame members shall be coped to form tight butt joints where joined to perimeter members. All joinery fastened securely with stainless steel self-tapping screws and sealed to prevent moisture and air infiltration. Extruded aluminum glass stops shall be fabricated to form tight butt-joints.

CASEMENT AND PROJECTED HARDWARE-

Casement and Projected shall be balanced with two heavy duty four bar friction hinges. Hinges shall be of stainless steel, and include a positive stop and an adjustable friction shoe. Locking hardware shall consist of cam handle locks and surface strikes. Handle, base & strike housing shall be cast white bronze with burnished finish.

WEATHERSTRIPPING-

A compression seal shall run continuously around entire perimeter of ventilator and frame opening of ventilator to form a double seal.

GLAZING-

Marlin series #7505 windows shall accept glazing materials with nominal thickness of 1".

OPTIONAL SCREEN-

Screen frames shall be fabricated from roll-form aluminum, finish to match window. Screen cloth to be 18 x 16 fiberglass mesh held in the aluminum screen frame with a tight fitting continuous vinyl spline.

INSTALLATION-

Windows shall be installed straight, plumb, and level without twisting and securely anchored in place. Openings shall be properly prepared to provide sufficient space at jambs, head and sill to compensate for normal construction movement without affecting intended use.

PROTECTION AND CLEANING-

The General Contractor shall provide adequate protection of the aluminum and glass surfaces from damage by grinding compound, lime, acids, cement or other contaminants. The General Contractor shall be responsible for final cleaning.

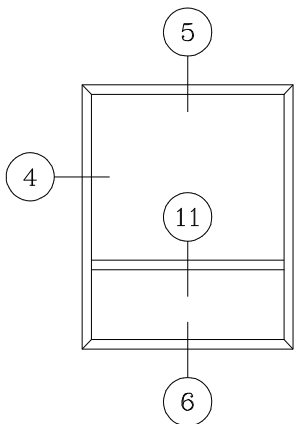
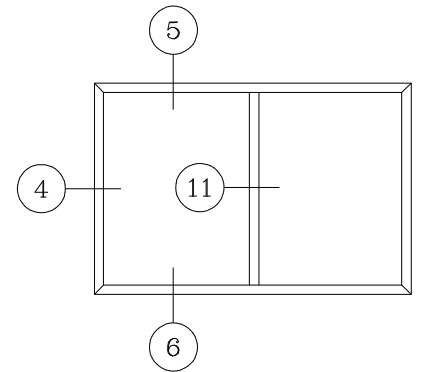
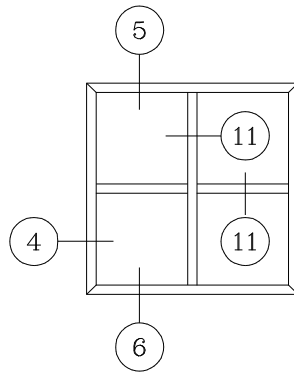
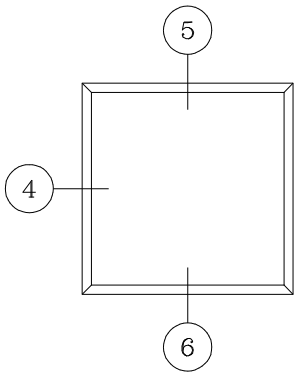
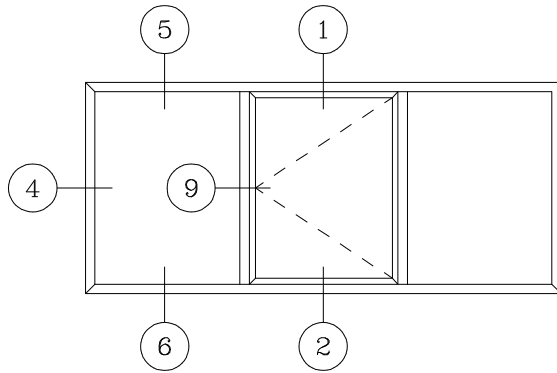
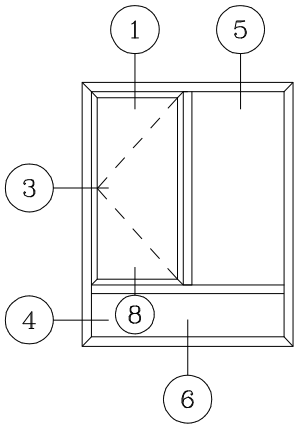
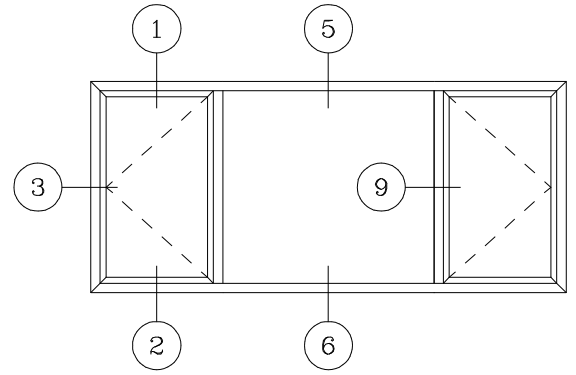
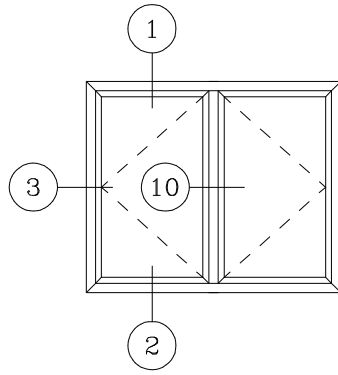
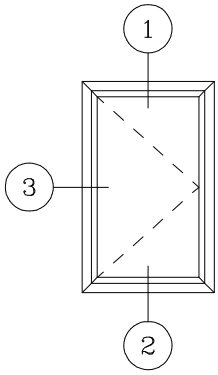

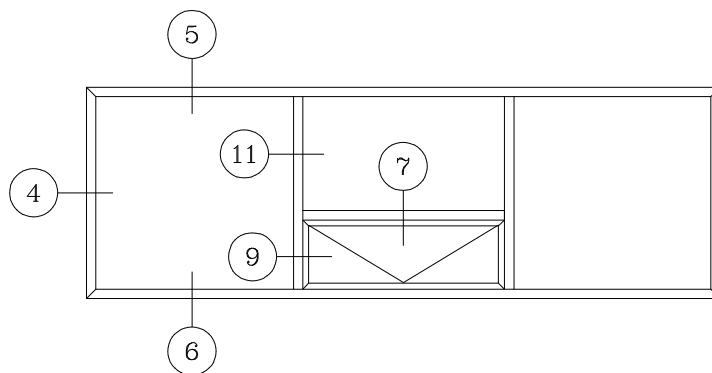
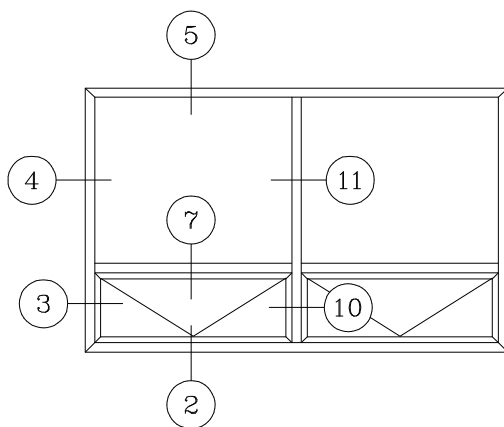
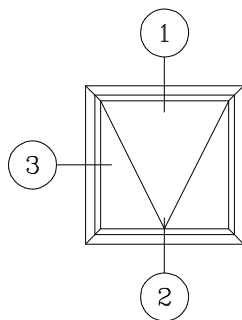



1 HEAD @ VENT

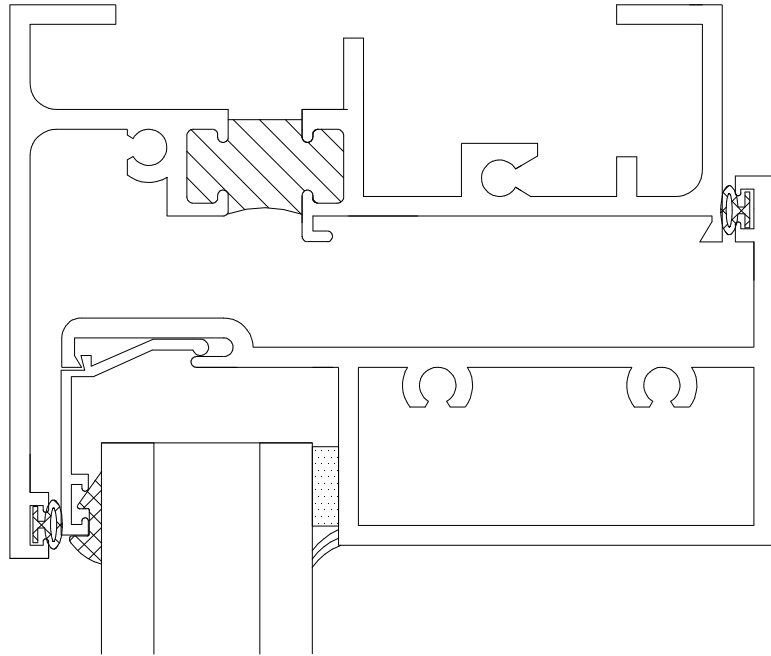

2 SILL @ VENT

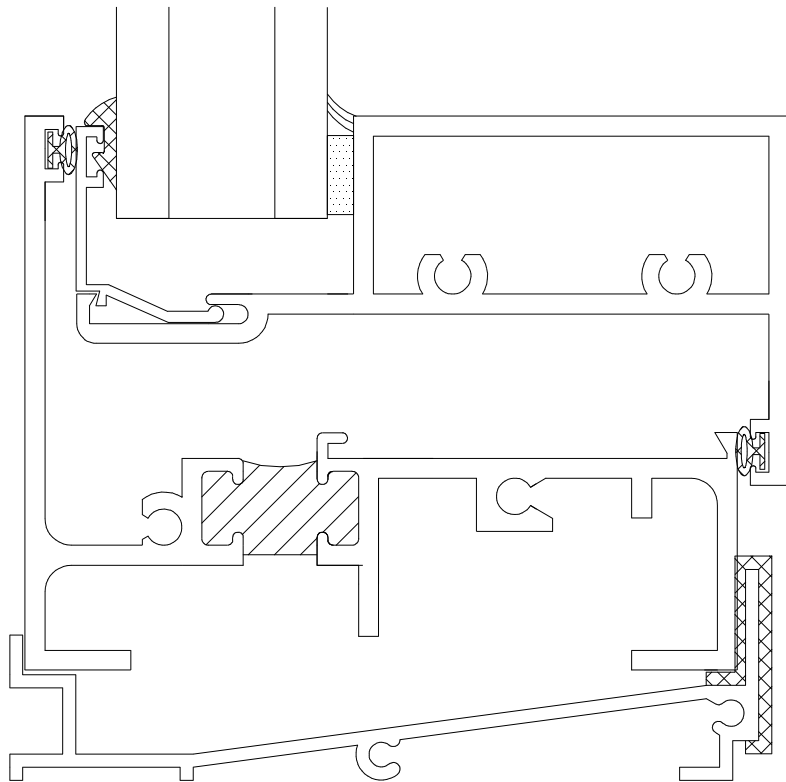

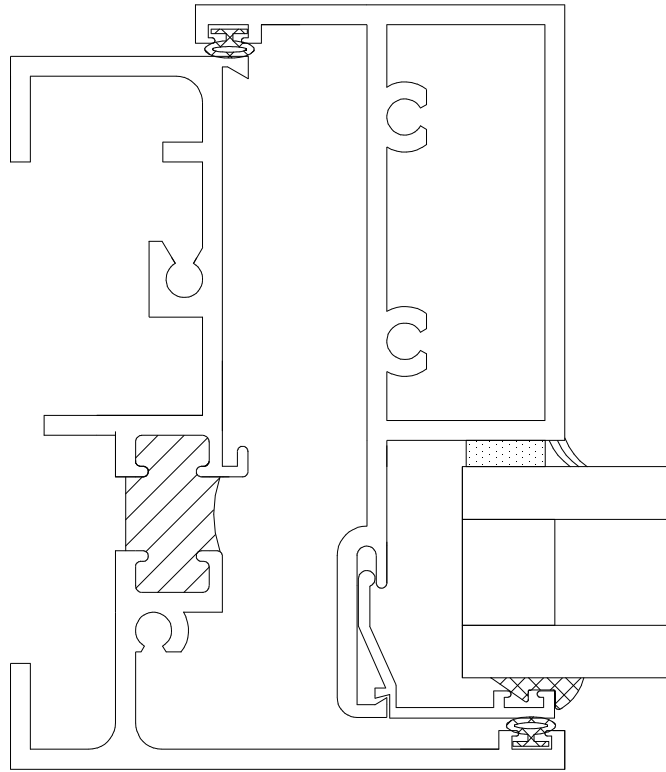

3 JAMB @ VENT

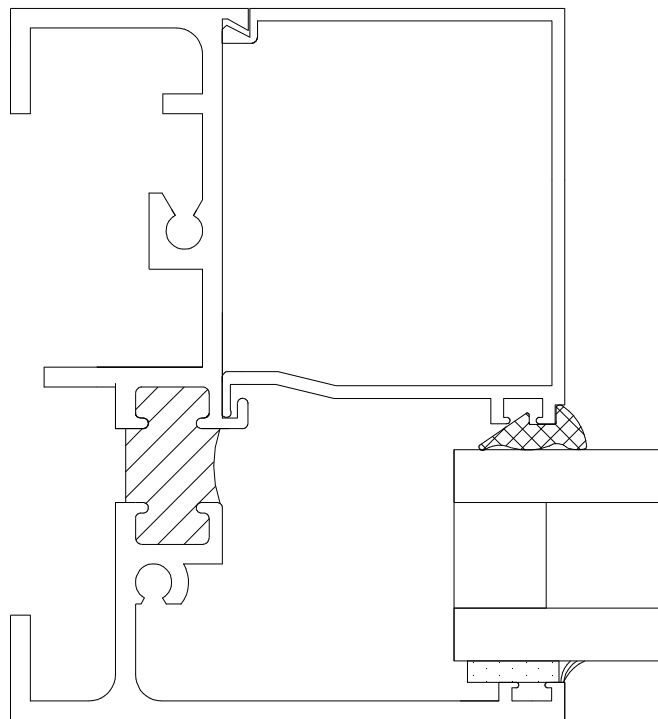

4 JAMB @ FIXED



5 HEAD @ FIXED

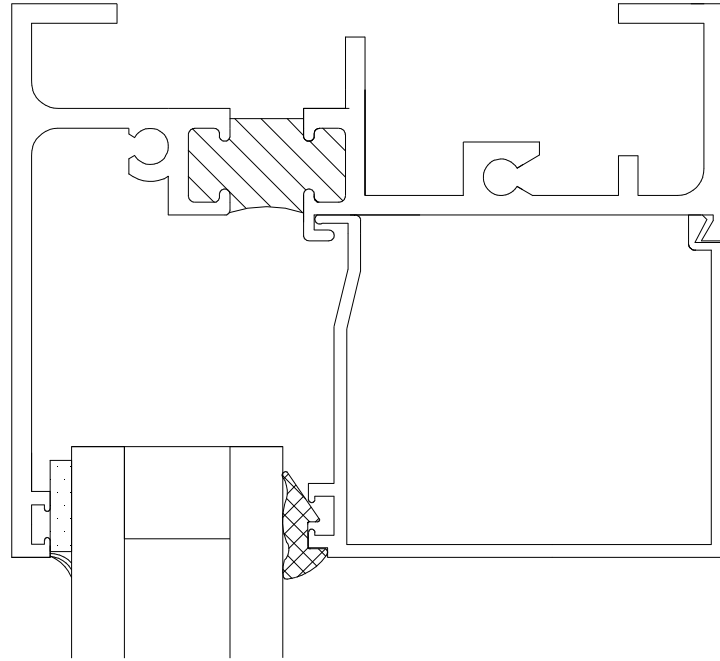

6 SILL @ FIXED

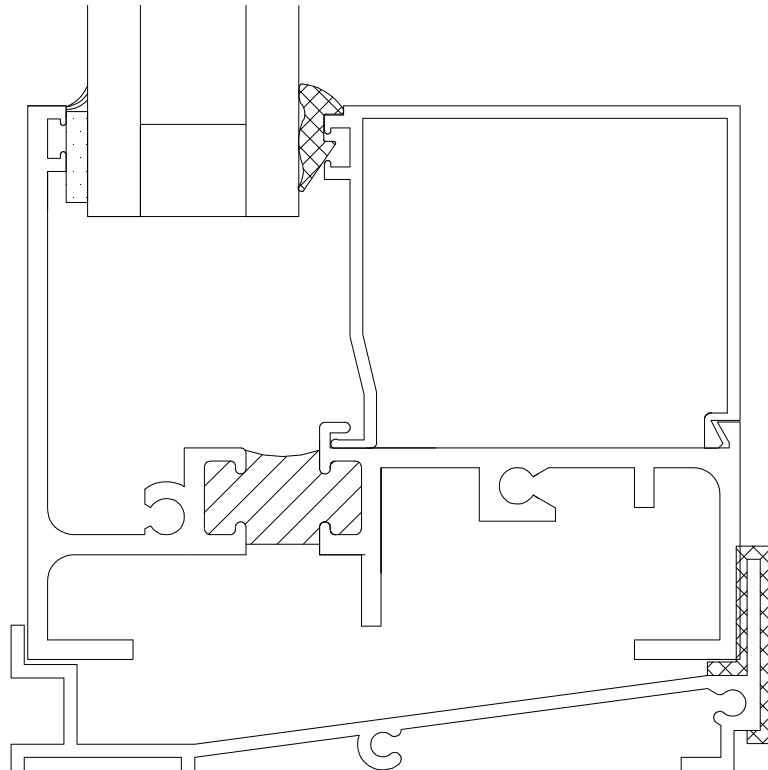

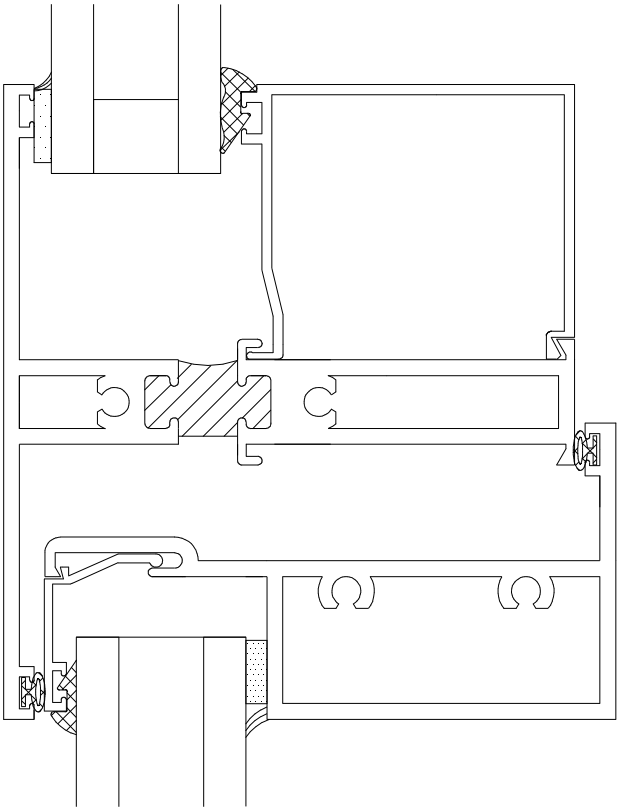

7 HORIZONTAL
VENT BELOW FIXED

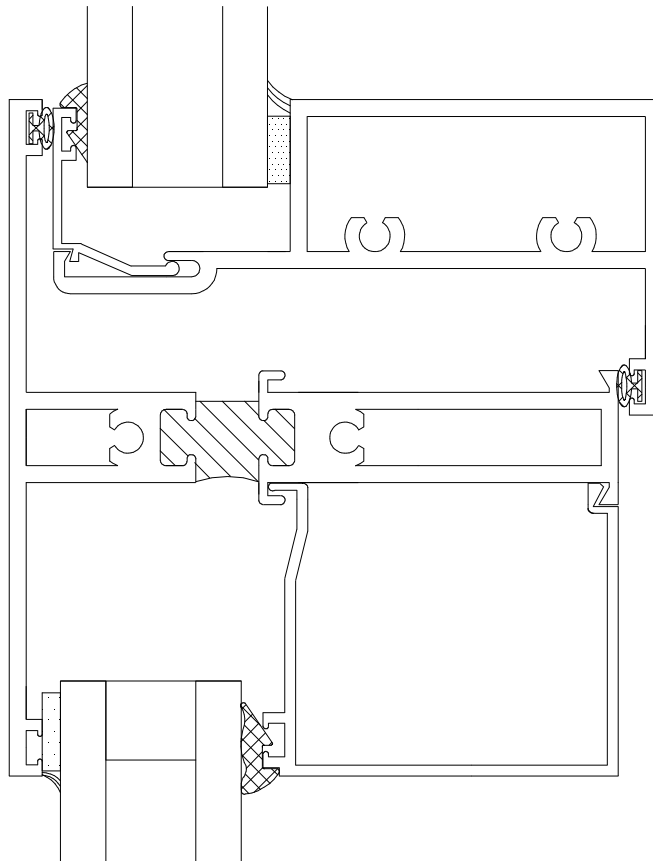

8 HORIZONTAL
VENT ABOVE FIXED

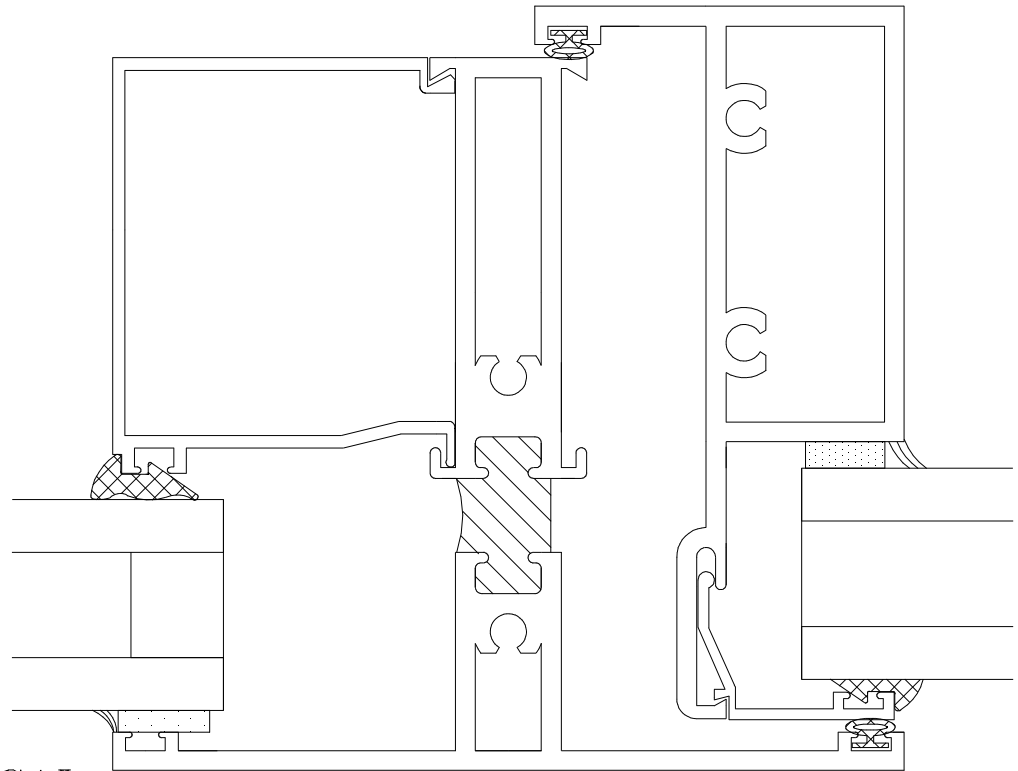

9

VERTICAL
VENT @ RIGHT OF FIXED

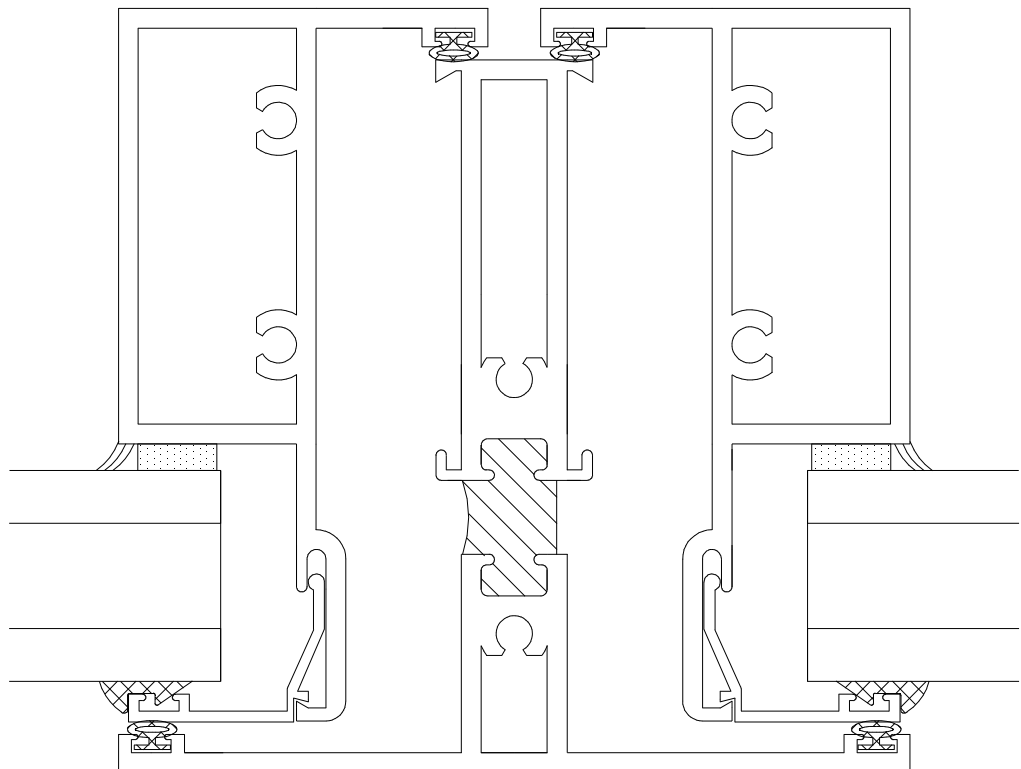

10

VERTICAL
@ DOUBLE VENT

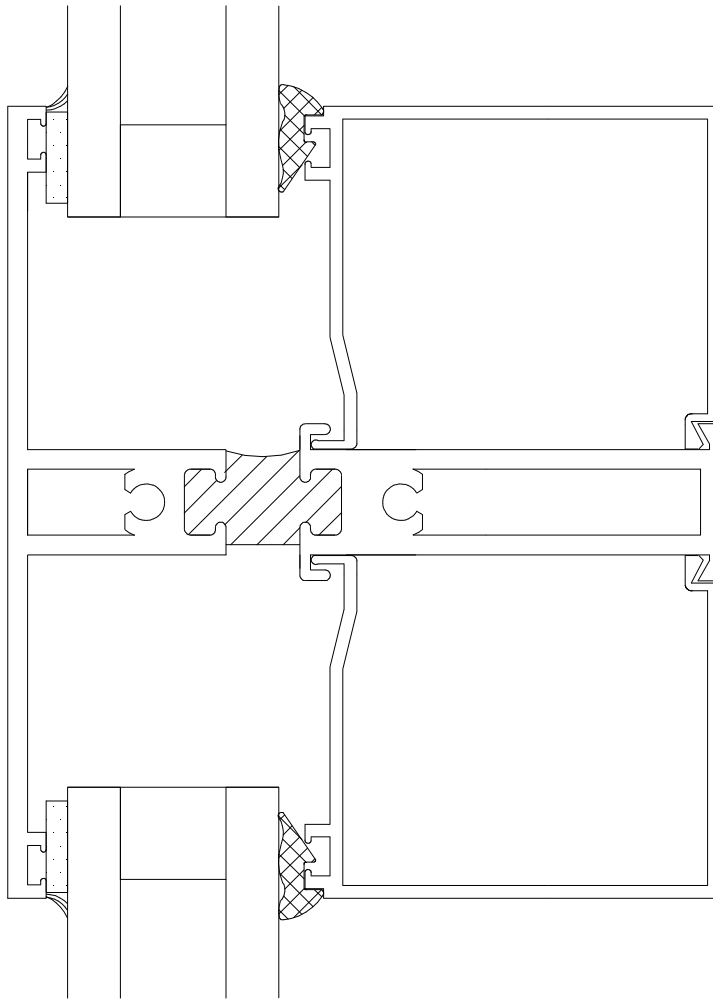

① 11 TYPICAL MULLION

"F" CLIP

